

Techcon Systems
TS5620 Series
Diaphragm Valve

User Guide



CONTENTS

	Page number
1. Specifications - Horizontal Valve.....	3
2. Specifications -Vertical Valve.....	4
3. Unpacking and Inspection.....	5
4. Description.....	5
5. Theory of Operation.....	5
6. Setup Instructions.....	6
7. Typical System Set-Up.....	7
8. Maintenance and Cleaning.....	8-9
9. Spare Parts.....	10-11
10. Repair Kits.....	12
11. Accessories.....	13
12. Troubleshooting.....	14
13. Warranty.....	15

13. LIMITED WARRANTY

Manufacturer warrants this product to the original purchaser for a period of one (1) year from date of purchase to be free from defects in material and workmanship, but not against damages by misuse, negligence, accident, faulty installations and instructions. Manufacturer will repair or replace (at factory's option), free of charge, any component of the equipment thus found to be defective, on return of the component, "PREPAID" to the factory during the warranty period. In no event shall any liability or obligation of the Manufacturer arising from this warranty exceed the purchase price of the equipment. This warranty is only valid if the defective product is returned as a complete assembly without physical damage. The Manufacturer's liability, as stated herein, cannot be altered or enlarged except by a written statement signed by an officer of the company. In no event shall the Manufacturer be liable for consequential or incidental damages. A return authorization is required from Techcon Systems prior to shipping a defective unit to the factory.

Manufacturer reserves the right to make engineering product modifications without notice.

All returns must be issued with a Returns Authorization number, prior to return. Send warranty returns to:

Americas and Asia

OK International
Garden Grove Division
12151 Monarch Street
Garden Grove, Ca 92841

Europe

OK International
Eagle Close
Chandler's Ford Ind Est
Eastleigh
Hampshire
SO53 4NF
United Kingdom

www.techconsystems.com

Delrin® and Teflon® is a registered trademark of E.I. DuPont.

12. TROUBLE SHOOTING

PROBLEM	POSSIBLE CAUSE	CORRECTION
No fluid flow	Fluid pressure too low	Increase fluid pressure
	Operating pressure too low	Increase air pressure to 70 psi (4.8bar)
	Dispense tip clogged	Replace tip
	Fluid cured in valve chamber	Clean valve thoroughly
	Stroke adjustment closed	Open stroke adjustment counterclockwise
Inconsistent fluid flow	Fluid pressure fluctuating	Make sure fluid pressure is constant
	Valve operating pressure is too low	Increased valve pressure to 70 psi (4.8bar)
	Valve open time is not consistent	Check to make sure the valve controller is providing a consistent output
	Air trapped in fluid housing	Purge valve
Fluid drools after the valve closes, eventually stopping	Air trapped in fluid housing	Purge valve
Steady drip	Worn diaphragm	Replace diaphragm
	Worn fluid housing	Replace fluid housing
	Fluid pressure exceeds 70 psi (4.8bar)	Lower fluid pressure
	Valve reassembled incorrectly after cleaning	Refer to maintenance section

1. SPECIFICATIONS – Horizontal Diaphragm Valve

	TS5620HT	TS5620HU	TS5621HD
Size	2.47" Length X 0.94" (62.74mm X 23.88mm)	2.47" Length X 0.94" (62.74mm X 23.88mm)	2.47" Length X 1.06" (62.74mm X 26.90mm)
Weight	0.15 lb (69g)	0.13 lb (60g)	0.15 lb (70g)
Fluid Inlet Port	1/4-28 UNF	1/4-28 UNF	1/8" NPT female
Fluid Outlet Port	1/4-28 UNF	1/4-28 UNF	1/8" NPT female
Air Inlet Port	10-32 UNF	10-32 UNF	10-32 UNF
Auxiliary Air Inlet Port	10-32 UNF	10-32 UNF	10-32 UNF
Minimum Air Pressure	70 psi (4.8bar)	70 psi (4.8bar)	70 psi (4.8bar)
Maximum Fluid Pressure	70 psi (4.8bar)	70 psi (4.8bar)	70 psi (4.8bar)
Operating Frequency	Exceeds 500 cycles/min.	Exceeds 500 cycles/min.	Exceeds 500 cycles/min.
Mounting Port	10-32 UNF	10-32 UNF	10-32 UNF
Wetted Parts	Teflon®	UHMWPE	UHMWPE, Delrin®

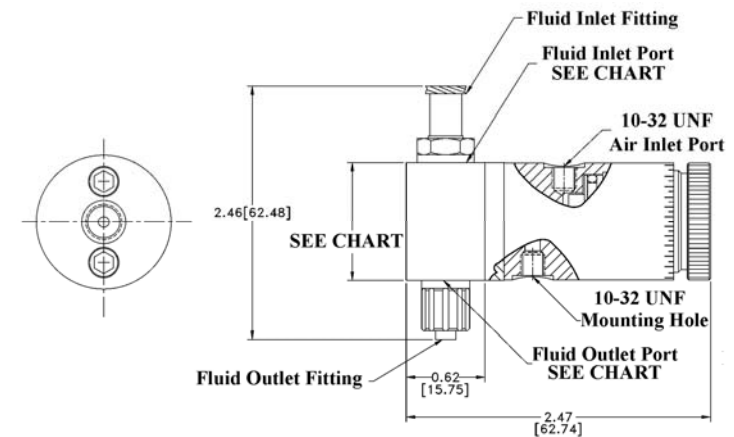

Dimensions are in inches [mm]

Figure 1.0

2. SPECIFICATIONS – Vertical Diaphragm Valve

	TS5622VT	TS5622VU	TS5622VD
Size	2.63" Length X 1.06" (66.80mm X 26.90mm)	2.63" Length X 1.06" (66.80mm X 26.90mm)	2.63" Length X 1.06" (66.80mm X 26.90mm)
Weight	0.18 lb (80g)	0.14 lb (64g)	0.16 lb (71g)
Fluid Inlet Port	1/8" NPT female	1/8" NPT female	1/8" NPT female
Fluid Outlet Port	1/4-28 UNF	1/4-28 UNF	1/4-28 UNF
Air Inlet Port	10-32 UNF	10-32 UNF	10-32 UNF
Auxiliary Air Inlet Port	10-32 UNF	10-32 UNF	10-32 UNF
Minimum Air Pressure	70 psi (4.8bar)	70 psi (4.8bar)	70 psi (4.8bar)
Maximum Fluid Pressure	70 psi (4.8bar)	70 psi (4.8bar)	70 psi (4.8bar)
Operating Frequency	Exceeds 500 cycles/min.	Exceeds 500 cycles/min.	Exceeds 500 cycles/min.
Mounting Port	10-32 UNF	10-32 UNF	10-32 UNF
Wetted Parts	Teflon®	UHMWPE	UHMWPE, Delrin®

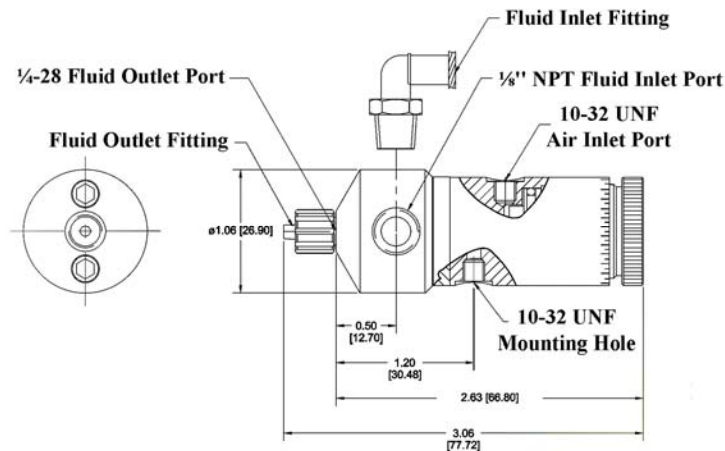

Dimensions are in inches [mm]

Figure 2.0

11. ACCESSORIES

PART NUMBER	DESCRIPTION
TS918-46	4-Way Fluid Manifold
TN00DKIT	Complete Dispensing Tip Kit
9000-000-100	Sample Tip Kit

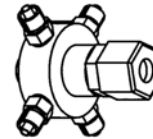

11.1 FLUID FITTINGS AND TUBING

PART NUMBER	DESCRIPTION
TSD1003-16	1/8" NPT to 1/4" O.D. Tube, 90° Elbow
TSD1002-17	1/8" NPT to 3/8" O.D. Tube
TSD1002-18	1/8" NPT to 1/4" O.D. Tube
TSD1002-38	1/4" NPT to 1/4" O.D. Tube
TSD1099-22	3/8" O.D. X 1/4" I.D. Tube, Black, Polyethylene
TSD1099-23	3/8" O.D. X 1/4" I.D. Tube, Clear, Polyethylene
TSD1099-24	1/4" O.D. X 1/8" I.D. Tube, Clear, Polyethylene
TSD1099-25	1/4" O.D. X 1/8" I.D. Tube, Black, Polyethylene
TSD1099-45	6mm O.D. X 4mm I.D, Clear, Polyethylene
TSD1099-46	6mm O.D. X 4mm I.D, Black, Polyethylene
TSD126-360BPK	Luer Lock Tubing, 60" (1524mm) , Black

11.2 BRACKETS

PART NUMBER	DESCRIPTION
918-033-000	Productions Master Stand (Base & Support)
918-000-012	Rod Clamp Assembly
5620-000-008	4" (101.6mm) Threaded Mounting Rod

10. REPAIR KITS – Diaphragm and Fluid Housing Repair Kits

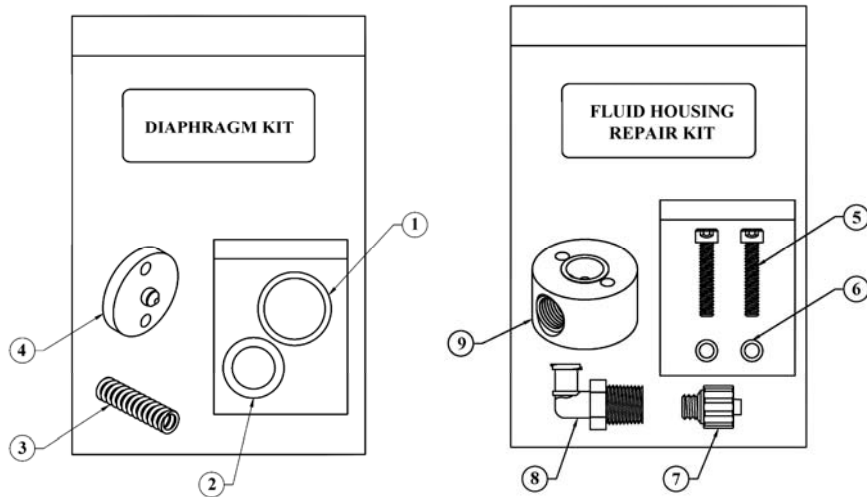

ITEM	PART NUMBER	DESCRIPTION	QTY
1	TSD1400-016A	Piston O-Ring	1
2	TSD1400-111A	End Cap O-Ring	1
3	TSD1150-40	Spring	1
4	REFER TO PREVIOUS PARTS LIST	Diaphragm	1
5	TSD1103-336	Fluid Housing Screw	2
6	TSD1109-53	Flat Washer	2
7	REFER TO PARTS LIST	Tip Adaptor	1
8	REFER TO PARTS LIST	Inlet Adaptor	1
9	REFER TO PARTS LIST	Fluid Housing	1

Recommended Repair Kits For Diaphragm Valves:

VALVE	FLUID HOUSING KIT	DIAPHRAGM KIT
TS5620HT	5620HT-FHKIT	5620TFE-DKIT
TS5620HU	5620HU-FHKIT	5620UHMW-DKIT
TS5621HD	5621HD-FHKIT	5620UHMW-DKIT
TS5622VT	5622VT-FHKIT	5620TFE-DKIT
TS5622VU	5622VU-FHKIT	5620UHMW-DKIT
TS5622VD	5622VD-FHKIT	5620UHMW-DKIT

3. UNPACKING AND INSPECTION

Carefully unpack the valve and examine the items contained in the carton. These will include:

- Valve Assembly
- Valve bracket, rod and air hose
- 2 x Hex keys
- Sample tip kit and fluid line
- User guide

4. DESCRIPTION

The TS5620 Series Diaphragm Valves are designed to dispense low to medium viscosity fluids. An internal spring return makes the valve fully adaptable for use with any time/pressure controller. A short opening stroke provides extremely fast, positive shut-off. An external stroke control adjustment makes it easy to fine tune shot sizes. The TS5620 Series Diaphragm Valves compact design allows for mounting flexibility and easy integration into automated applications.

5. THEORY OF OPERATION (Refer to figure 3.0)

The TS5620 Series Diaphragm Valves are normally closed, adjustable stroke valves. Input air pressure of 70-90 psi (4.8 to 6.2bar) through air inlet port (1) drives the piston assembly (2) back, opening the material path, allowing fluid flow from the material inlet (3) to the material outlet (4). Relieving the input air pressure allows the piston return spring (5) to close the diaphragm (6), ensuring rapid “fail-safe” shut-off of fluid flow.

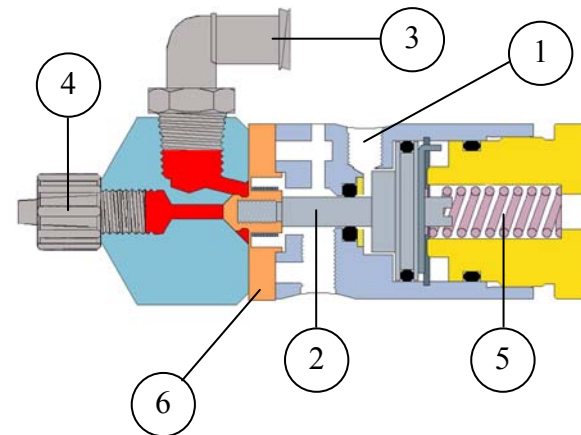

Figure 3.0

6. SETUP INSTRUCTIONS

Refer to Figure 4.0

Note: This installation uses Luer lock adapters shipped with the valve. Any approved material line with 1/8" NPT connections will work.

1. Connect the fluid reservoir feed tube to the valve inlet port (1).
2. Connect the valve airline to the valve controller or other pneumatic device that is used to control the valve.
3. Connect appropriate dispensing tip or nozzle to the fluid outlet port (3).
4. Set the valve controller pressure at 70 psi (4.8bar)
5. Set the fluid reservoir pressure. Do not exceed 70 psi (4.8bar)
6. Make sure all connections are tight
7. Place container under the outlet and activate the valve until the fluid flows steady

The amount of fluid that flows through the valve is determined by:

- Valve open time
- Fluid reservoir pressure
- Dispensing tip size

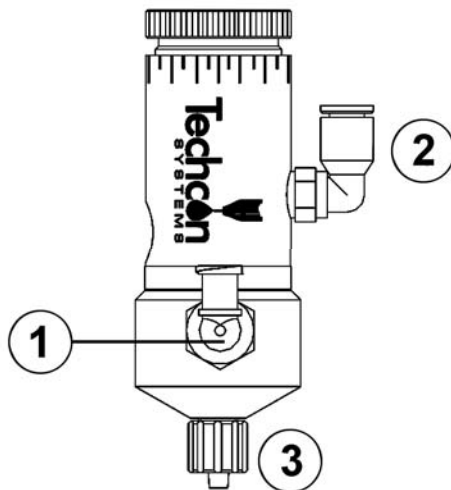
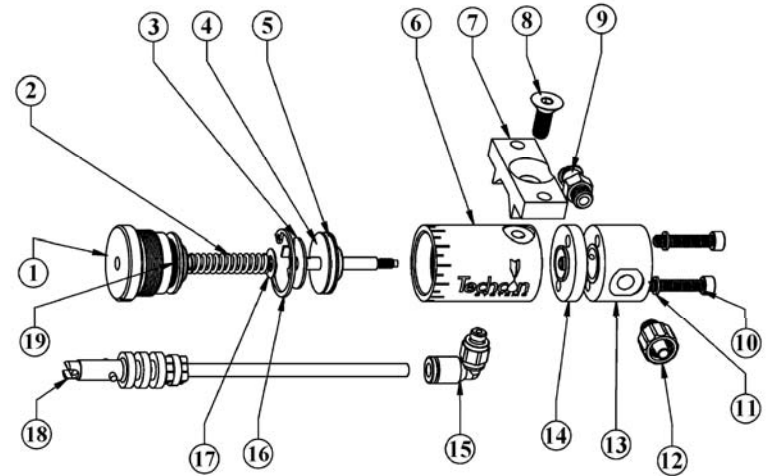

Figure 4.0

SPARE PARTS, CONT - Horizontal Valve



ITEM	PART NUMBER	DESCRIPTION	QTY
1	5620-000-004	End Cap	1
2	TSD1150-40	Spring	1
3	5620-000-006	Anti-Rotate Washer	1
4	5620-000-005	Piston	1
5	TSD1400-016A	Piston O-Ring	1
6	5620-000-003	Air Cylinder	1
7	918-000-048	Mounting Bracket	1
8	TSD1106-13	Mounting Screw	1
9	TSD931-58	Inlet Adaptor For TS5620HT/TS5620HU	1
9*	TSD931-54	Inlet Adaptor For TS5621HD	1
10	TSD1103-336	Fluid Housing Screw	2
11	TSD1109-53	Flat Washer	2
12	TSD931-60	Tip Adaptor for TS5620HT/TS5620HU	1
12*	TSD931-57	Tip Adaptor for TS5621HD	1
13	5620HT-000-001	Fluid Housing for TS5620HT	1
13*	5620-000-001	Fluid Housing for TS5620HU	1
13*	5621-000-001	Fluid Housing for TS5621HD	1
14	5620-000-011	Diaphragm for TS5620HT	1
14*	5620-000-002	Diaphragm for TS5621HD/TS5620HU	1
15	TSD1003-20	Air Fitting, 4mm, Elbow	1
16	TSD1120-11	Retaining Ring	1
17	TSD1109-43	Mylar Washer	1
18	A0100478	Air Hose/Connector Assembly, 4mm	1
19	TSD1400-111A	End Cap O-Ring	1

9. SPARE PARTS - Vertical Valve

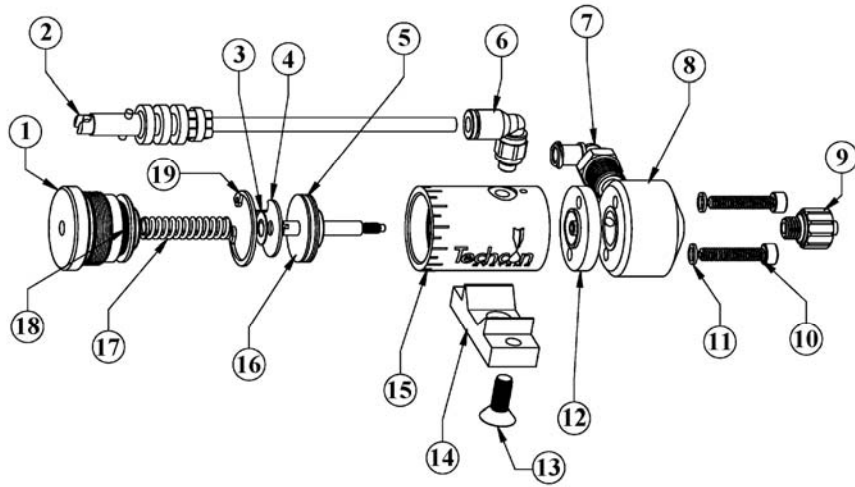

ITEM	PART NUMBER	DESCRIPTION	QTY
1	5620-000-004	End Cap	1
2	A0100478	Air Hose/Connector Assembly, 4mm	1
3	TSD1109-43	Mylar Washer	1
4	5620-000-006	Anti-Rotate Washer	1
5	TSD1400-016A	Piston O-Ring	1
6	TSD1003-20	Air Fitting, 4mm, Elbow	1
7	TSD931-75	Luer Lock Adaptor, Elbow	1
8	5622-000-003	Fluid Housing for TS5622VT	1
8*	5622-000-001	Fluid Housing for TS5622VU	1
8*	5622D-000-001	Fluid Housing for TS5622VD	1
9	TSD931-60	Tip Adaptor for TS5622VT/TS5622VU	1
9*	TSD931-91	Tip Adaptor for TS5622VD	1
10	TSD1103-336	Fluid Housing Screw	2
11	TSD1109-53	Flat Washer	2
12	5620-000-011	Diaphragm for TS5622VT	1
12*	5620-000-002	Diaphragm for TS5622VU/TS5622VD	1
13	TSD1106-13	Mounting Screw	1
14	918-000-048	Mounting Bracket	1
15	5620-000-003	Air Cylinder	1
16	5620-000-005	Piston	1
17	TSD1150-40	Spring	1
18	TSD1400-111A	End Cap O-Ring	1
19	TSD1120-11	Retaining Ring	1

7. TYPICAL SYSTEM SET-UP

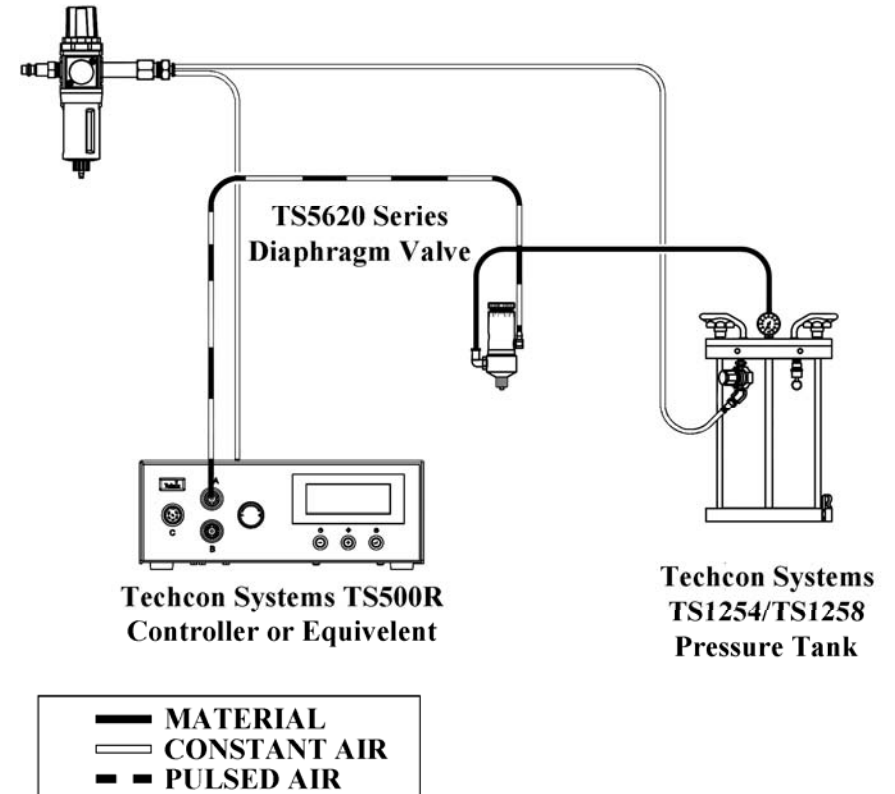

Figure 5.0

8. MAINTENANCE AND CLEANING

Normally, purging the valve with appropriate flush material or solvent after use is sufficient for cleaning. However some material may cause a buildup in the valve chamber, in this case periodic and thorough cleaning will be required.

CAUTION: Make sure fluid pressure is released before valve disassembly.

8.1 Cleaning (Refer to figure 6.0)

1. Release fluid pressure
2. Disconnect fluid line
3. Disconnect valve air line
4. Remove the two socket head cap screws (8) from the fluid housing (6)
5. Pull the fluid housing (6) away from the air cylinder assembly (12)
6. Clean Diaphragm (5) and fluid housing (6)

NOTE: Avoid using sharp probes for cleaning. Any nicks or scratches on the sealing surfaces may cause leakage.

7. Reinstall the fluid housing (6).
8. Align the fluid housing mounting holes with the diaphragm and air cylinder holes.
9. Reinstall the two socket head cap screws (8). Tighten in accordance with the Torque specifications chart on page 9.

8.2 To Change the Diaphragm (Refer to figure 6.0)

Tool required: Flat tip screwdriver, Retaining Ring Removal Tool, 7/64" hex wrench.

1. Remove the two socket head cap screws (8) from the fluid housing (6)
2. Pull the fluid housing away from the air cylinder assembly (12)
3. Remove the old diaphragm (5) by unscrewing it in the counterclockwise direction.
4. Install the new diaphragm by threading it in the clockwise direction. Make sure the internal thread on the diaphragm is not stripped or cross-threaded.
5. Hand tightened the diaphragm until it bottoms against shoulder on piston rod. At this point, do not over tighten or loosen the diaphragm to align the diaphragm and air cylinder holes.
6. The valve is designed so that the fluid housing can be rotated in 45° increments to allow for material input/output alignment. For alignment, insert a small flat tip screwdriver through the hole in the stroke control knob (10) and engage the piston rod slot. Turn the screwdriver clockwise to rotate the rod, piston and diaphragm assembly until the appropriate holes are aligned.
7. Reinstall the fluid housing (6).
8. Align the fluid housing mounting holes with diaphragm and air cylinder holes.
9. Reinsert the two socket head cap screws (8). Tighten in accordance with the Torque specifications chart on page 9.

8.3 7. To Change or Lubricate Piston O-ring (Refer to figure 6.0)

1. Remove the fluid housing (6).
2. Remove the diaphragm (5).
3. Remove the stroke control knob (10) and spring (11).
4. Remove the retaining ring (1) and anti-rotating washer (2).
5. Remove the piston assembly (13).
6. Replace o-ring (4) if damaged; otherwise lubricate o-ring with Bimba HT-99, or equivalent.
7. Reinstall piston (13), retaining ring (1) and anti-rotating washer (2).
8. Reinstall spring (11) and stroke control knob (10).
9. Reinstall diaphragm (5) and fluid housing (6).

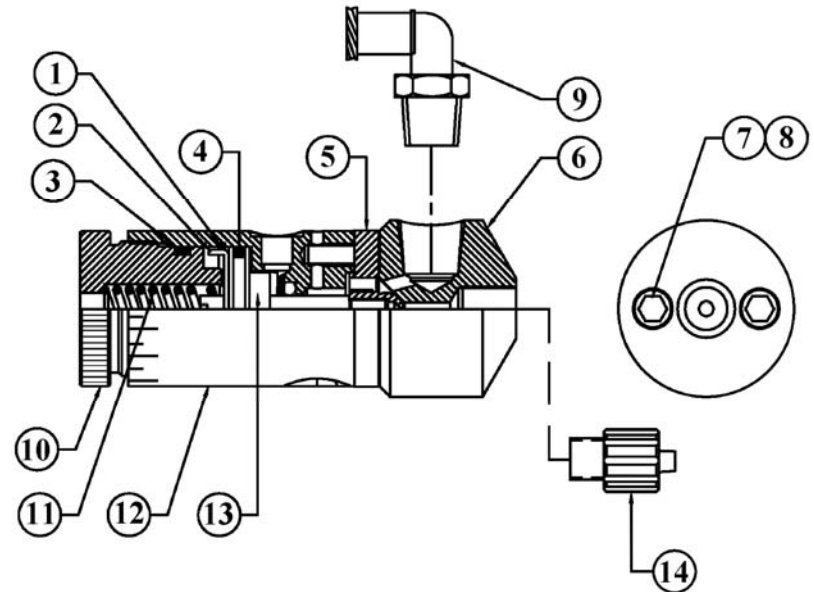

Figure 6.0

FLUID HOUSING MATERIAL	TORQUE SPECIFICATIONS
Acetal (Delrin®)	14 in lb (1.58 N-m)
UHMW	7 in lb (0.79 N-m)
Teflon®	5 in lb (0.56 N-m)